

Tubular handles

Tube Aluminium or Stainless Steel

SPECIFICATION

Tube Ø 30 x 1.5

Aluminium / Stainless Steel

Handle shanks / cover caps

Plastic (Polyamide PA)

- glass fibre reinforced
- temperature resistant up to 100 °C

Tube Aluminium

plastic coated

black, RAL 9005, textured finish **SW**

Handle shanks / cover caps, black, matt

Tube Aluminium

anodized, natural colour **EL**

Handle shanks / cover caps, black, matt

Tube Aluminium

anodized, natural colour **ELG**

Handle shanks / cover caps, light grey, matt

Tube Stainless Steel AISI 304

ground, matt shiny finish **NG**

Handle shanks / cover caps, black, matt



INFORMATION

Owing to their large range of variants and their classic design, GN 666.1 tubular handles are the perfect choice for many applications.

With the modular structure, special lengths are available even in comparatively small unit quantities. Large handle can be supplied with additional centre struts.

TECHNICAL INFORMATION

- Load rating information (see page A35)

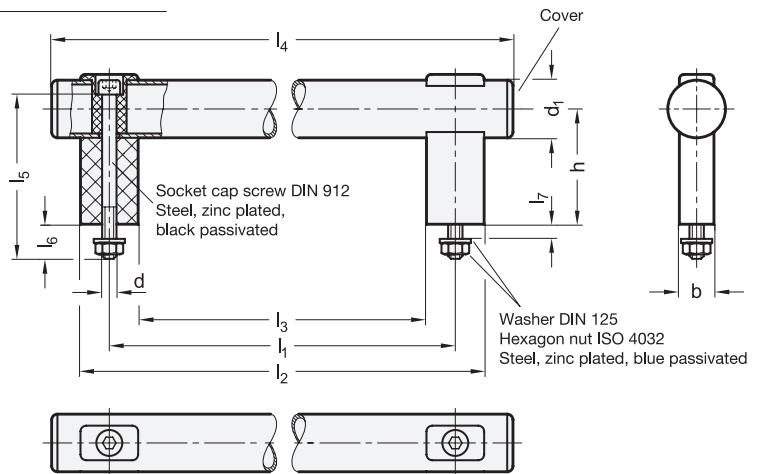

* Complete with Finish of the Tubular handles (SW, WS, EL, ELG or NG)

SW	WS	EL	ELG	NG
black	white	anodized, black	anodized, light grey	Stainless Steel, black

GN 666.1

Description	d1	l1 ±0.5	b	d2	h	l2	l3	l4	l5	l6	l7 max.	⚖
GN 666.1-30-200-*	30	200	18	M 8	60	230	170	265	85	17	8.5	247
GN 666.1-30-250-*	30	250	18	M 8	60	280	220	315	85	17	8.5	265
GN 666.1-30-300-*	30	300	18	M 8	60	330	270	365	85	17	8.5	284
GN 666.1-30-400-*	30	400	18	M 8	60	430	370	465	85	17	8.5	321
GN 666.1-30-500-*	30	500	18	M 8	60	530	470	565	85	17	8.5	357
GN 666.1-30-600-*	30	600	18	M 8	60	630	570	665	85	17	8.5	394

